

TRACK PROFILE

SCALE : 1:2

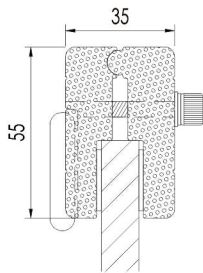

ROLLER PROFILE

SCALE : 1:2

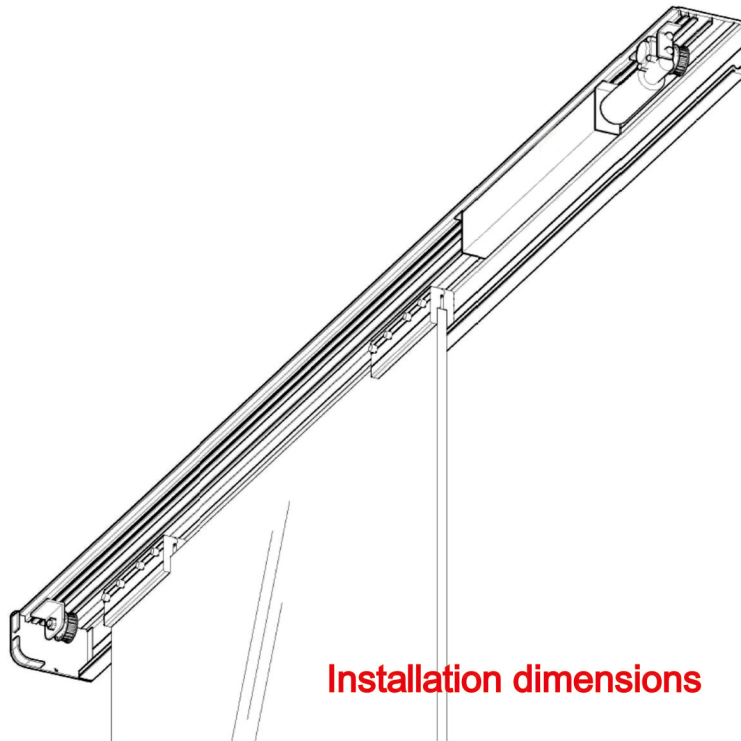

Installation dimensions



Technical Parameters

Horizontal pull	Single Door	Double Doors
Leaf weight	≤ 100kg	≤ 80 * 2kg
Width of door	700 ~ 1300mm	600 ~ 1250mm
Controller	High-performance micro-controller	High-performance micro-controller
Motor	DC 24V 45W brushless motor	DC 24V 45W brushless motor
Opening speed	≤ 400mm / s (adjustable)	≤ 400mm / s (adjustable)
Closing speed	≤ 300mm / s (adjustable)	≤ 300mm / s (adjustable)
Door hold time	0.5 ~ 10s (adjustable)	0.5~10 s (adjustable)
Manual thrust	≤ 45N	≤ 45N
Opening direction	Optional	Optional
Supply Voltage	AC85V~AC265V 50Hz ~ 60Hz	AC85V~AC265V 50Hz ~ 60Hz
Temperature	-20 ~ 50 C	-20 ~ 50 C
Humidity	35 ~ 85% RH (non-condensing)	35 ~ 85% RH (non-condensing)
Extensions	Safety light eyes, such as remote control of various types of access control	